

# COBRA

MODELS: CS35040VZ (DYM120201)

## COBRA CORDLESS CHAINSAW OWNER'S MANUAL



**Cobra Garden Machinery**

Henton and Chattell Ltd., London Road, Nottingham NG2 3HW UK

[www.cobragarden.co.uk](http://www.cobragarden.co.uk)





**⚠ WARNING :**



For your own safety please read this manual before attempting to operate your new unit. Failure to follow instructions can result in serious personal injury. Spend a few moments to familiarize yourself with your garden tool before each use. Keep this manual in a safe place, so that the information is available at all times. If you give the equipment to any other person, hand over these operating instructions and safety regulations as well.

## CONTENTS

SECTION 1	SYMBOLS MARKED ON THE PRODUCT.....	3
SECTION 2	GENERAL SAFETY RULES.....	5
SECTION 3	PARTS DESCRIPTION.....	15
SECTION 4	TECHNICAL DATA.....	16
SECTION 5	ASSEMBLY.....	16
SECTION 6	OPERATING THE CHAIN SAW.....	20
SECTION 7	CUTTING .....	22
SECTION 8	MAINTENANCE AND CLEANING.....	25
SECTION 9	TROUBLESHOOTING.....	28
SECTION 10	WARRANTY .....	29
SECTION 11	ENVIRONMENTALLY FRIENDLY DISPOSAL.....	30
SECTION 12	EC-DECLARATION OF CONFORMITY .....	31

## 1. SYMBOLS MARKED ON THE PRODUCT

SYMBOLS	NAME	EXPLANATION
	CE Marking	The product meets the demands and regulations set by the European Community (now European Union).
	WEEE marking	CAUTION! Unusable power tools do not belong with domestic waste. They must be taken to a communal collecting point for environmentally friendly disposal in accordance with local regulations.
	Read the operator's instructions	To reduce the risk of injury. User must read and understand operator's manual before using this product.
	Do not expose to rain	Don't leave your tool exposed to outdoor or rain.
	Wear eye protection	To reduce the risk of you eye, please wear eye protection !

	Wear ear protection	please wear ear protection – to protect your hearing!
	Keep bystanders away	Keep all bystanders away.
	Noise level marking	Your tool noise is not more than 102dB.

#### Accumulator Disposal:

Old accumulators and batteries must not be added to household waste, but should be disposed of in accordance with the applicable legislation. Take unusable rechargeable batteries to the dealer's or community's battery collection point.

Disposing of the packaging: The packaging is made of cardboard and separately labeled foil which is also recyclable.

Take these materials to a recycling centre.

#### Battery packs/batteries:



#### Li-Ion

Do not dispose of batteries into household waste. Keep away from water or fire. Battery packs/batteries must be collected, recycled or disposed of in an environmentally-friendly way.

#### Only for EC countries:

Defective or dead batteries must be recycled according to the directive 2006/66/EC

## 2. GENERAL SAFETY RULES

### General Power Tool Safety Warnings

#### **▲ WARNING :**

Read all safety warnings and all instructions. Failure to follow the warnings and instructions may result in electric shock, fire and/or serious injury. Save all warnings and instructions for future reference.

The term “power tool” in the warnings refers to your mains-operated (corded) power tool or battery operated (cordless) power tool.

### 2.1 WORK AREA SAFETY

a) Keep work area clean and well lit. Cluttered or dark areas invite accidents.

b) Do not operate power tools in explosive atmospheres, such as in the presence of flammable liquids gases or dust. Power tools create sparks which may ignite the dust or fumes

c) Keep children and bystanders away while operating a power tool. Distractions can cause you to lose control. Set a

safe working area.

## **2.2 PERSONAL SAFETY**

a) Stay alert, watch what you are doing and use common sense when operating a power tool. Do not use a power tool while you are tired or under the influence of drugs, alcohol or medication. A moment of distraction while operating power tools may result in serious personal injury.

b) Use personal protective equipment. Always wear eye protection. Protective equipment such as dust mask, non-skid safety shoes, hard hat, or hearing protection used for appropriate conditions will reduce personal injuries.

c) Prevent unintentional starting. Ensure the switch is in the off-position before connecting to power source and/or battery pack, picking up or carrying the tool. Carrying power tools with your finger on the switch or energising power tools that have the switch on invites accidents.

d) Remove any adjusting key or wrench before turning the power tool on. A wrench or a key left attached to a rotating part of the power tool may result in personal injury.

e) Do not overreach. Keep proper footing and balance at all times. This enables better control of the power tool in unexpected situations.

f) Dress properly. Do not wear loose clothing or jewelry. Keep your hair, clothing and gloves away from moving parts. Loose clothes, jewelry or long hair can be caught in moving parts.

g) If devices are provided for the connection of dust extraction and collection facilities, ensure these are connected and properly used. Use of dust collection can reduce dust-related hazards.

## **2.3 POWER TOOL USE AND CARE**

a) Do not force the power tool. Use the correct power tool for your application. The correct power tool will do the job better and safer at the rate for which it was designed.

b) Do not use the power tool if the switch does not turn it on and off. Any power tool that cannot be controlled with the switch is dangerous and must be repaired.

c) Disconnect the plug from the power source and/or the battery pack from the power tool before making any adjustments, changing accessories, or storing power tools. Such preventive safety measures reduce the risk of starting the power tool accidentally.

d) Store idle power tools out of the reach of children and do not allow persons unfamiliar with the power tool or these



instructions to operate the power tool. Power tools are dangerous in the hands of untrained users.

e) Maintain power tools. Check for misalignment or binding of moving parts, breakage of parts and any other condition that may affect the power tool's operation. If damaged, have the power tool repaired before use. Many accidents are caused by poorly maintained power tools.

f) Keep cutting tools sharp and clean. Properly maintained cutting tools with sharp cutting edges are less likely to bind and are easier to control.

g) Use the power tool, accessories and tool bits etc. in accordance with these instructions, taking into account the working conditions and the work to be performed. Use of the power tool for operations different from those intended could result in a hazardous situation.

## **2.4 BATTERY TOOL USE AND CARE**

a) Recharge only with the charger specified by the manufacturer. A charger that is suitable for one type of battery pack may create a risk of fire when used with another battery pack.

b) Use power tools only with specifically designated battery packs. Use of any other battery packs may create a risk of

injury and fire.

c) When the battery pack is not in use, keep it away from other metal objects, like paper clips, coins, keys, nails, screws or other small metal objects, that can make a connection from one terminal to another. Shorting the battery terminals together may cause burns or a fire.

d) Under abusive conditions, liquid may be ejected from the battery; avoid contact. If contact accidentally occurs, flush with water. If liquid contacts eyes, additionally seek medical help. Liquid ejected from the battery may cause irritation or burns.

## **2.5 SERVICE**

Have your power tool serviced by a qualified repair person using only identical replacement parts. This will ensure that the safety of the power tool is maintained.

## **2.6 CHAIN SAW SAFETY WARNINGS**

a) Keep all parts of the body away from the saw chain when the chain saw is operating. Before you start the chain saw, make sure the saw chain is not contacting anything. A moment of distraction while operating a chain saw may cause entanglement of your clothing or body with the saw chain.

b) Always hold the Chain saw with your right hand on the rear handle and your left hand on the front handle. Holding the Chain saw with a reversed hand configuration increases the risk of personal injury and should never be done.

NOTE for chain saws designed with the guide bar on the left side, the reference to “right hand” and “left hand” positioning is reversed.

c) Wear safety glasses and hearing protection. Further protective equipment for head, hands, legs and feet is recommended. Adequate protective clothing will reduce personal injury by flying debris or accidental contact with the saw chain.

d) Do not operate a chain saw in a tree. Operation of a chain saw while up in a tree may result in personal injury.

e) Always keep a proper footing and operate the chain saw only when standing on a fixed, secure and level surface. Slippery or unstable surfaces such as ladders may cause a loss of balance or control of the chain saw.

f) When cutting a limb that is under tension be alert for spring back. When the tension in the wood fibres is released the spring loaded limb may strike the operator and/or throw the chain saw out of control.

g) Use extreme caution when cutting brush and saplings.

The slender material may catch the saw chain and be whipped toward you or pull you off balance.

h) Carry the chain saw by the front handle with the chain saw switched off and away from your body. When transporting or storing the chain saw always fit the guide bar cover. Proper handling of the chain saw will reduce the likelihood of accidental contact with the moving saw chain.

i) Follow instructions for lubricating, chain tensioning and changing accessories. Improperly tensioned or lubricated chain may either break or increase the chance for kickback.

j) Keep handles dry, clean, and free from oil and grease. Greasy, oily handles are slippery causing loss of control.

k) Cut wood only. Do not use chain saw for purposes not intended. For example: do not use chain saw for cutting plastic, masonry or non-wood building materials. Use of the chain saw for operations different than intended could result in a hazardous situation.

## **2.7 CAUSES AND OPERATOR PREVENTION OF KICKBACK**

Kickback may occur when the nose or tip of the guide bar touches an object, or when the wood closes in and pinches the saw chain in the cut.

Tip contact in some cases may cause a sudden reverse reaction, kicking the guide bar up and back towards the operator.

Pinching the saw chain along the top of the guide bar may push the guide bar rapidly back towards the operator.

Either of these reactions may cause you to lose control of the saw which could result in serious personal injury. Do not rely exclusively upon the safety devices built into your saw. As a chain saw user, you should take several steps to keep your cutting jobs free from accident or injury.

Kickback is the result of tool misuse and/or incorrect operating procedures or conditions and can be avoided by taking proper precautions as given below:

a) Maintain a firm grip, with thumbs and fingers encircling the chain saw handles, with both hands on the saw and position your body and arm to allow you to resist kickback forces. Kickback forces can be controlled by the operator, if proper precautions are taken. Do not let go of the chain saw.

b) Do not overreach and do not cut above shoulder height. This helps prevent unintended tip contact and enables better control of the chain saw in unexpected situations.

c) Only use replacement bars and chains specified by the manufacturer. Incorrect replacement bars and chains may

cause chain breakage and/or kickback.

d) Follow the manufacturer's sharpening and maintenance instructions for the saw chain. Decreasing the depth gauge height can lead to increased kickback.

## **2.8 SAFETY WARNINGS FOR BATTERY CHARGERS**

1. Keep the battery charger away from rain or moisture. Penetration of water in the battery charger increases the risk of an electric shock.

2. Do not charge other batteries. The battery charger is suitable only for charging lithium ion batteries within the listed voltage range. Otherwise there is danger of fire and explosion.

3. Keep the battery charger clean. Contamination can lead to danger of an electric shock.

4. Before each use, check the battery charger, cable and plug. If damage is detected, do not use the battery charger. Never open the battery charger yourself. Have repairs performed only by a qualified technician and only using original spare parts. Damaged battery chargers, cables and plugs increase the risk of an electric shock.

5. Do not operate the battery charger on easily inflammable surfaces (e. g., paper, textiles, etc.) or surroundings. The heating of the battery charger during the charging process can

pose a fire hazard.

6. Children should be supervised to ensure that they do not play with the battery charger.

### 3. PARTS DESCRIPTION

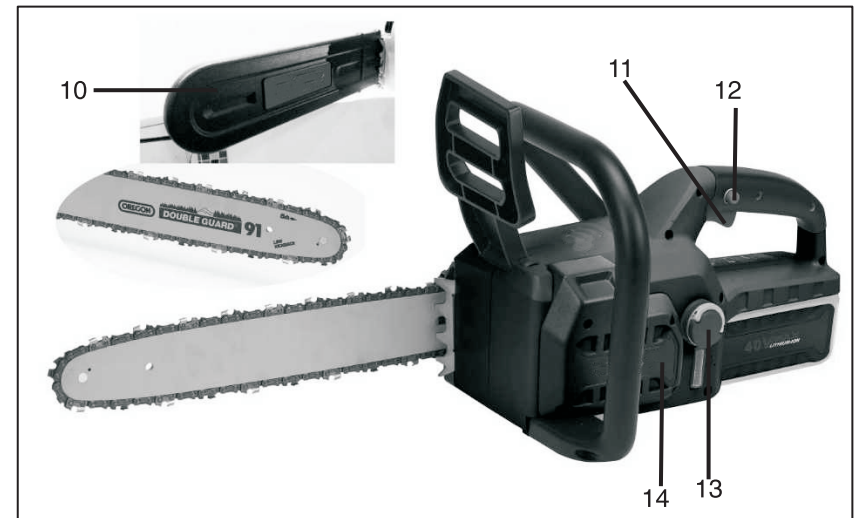
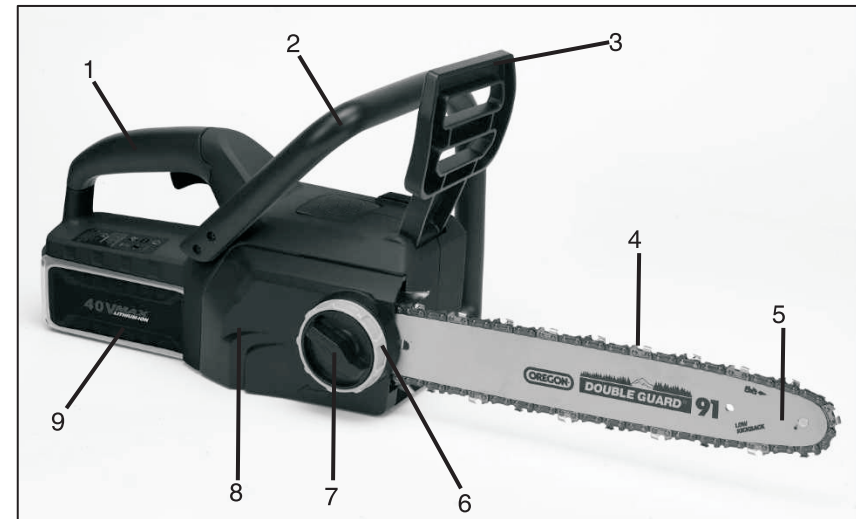

Fig.1

- |                       |                          |                                |                   |
|-----------------------|--------------------------|--------------------------------|-------------------|
| 1. Rear handle        | 2. Front handle          | 3. Hand guard                  | 4. Saw chain      |
| 5. Guide bar          | 6. Chain tensioning knob | 7. Bar adjustment locking knob | 8. Side cover     |
| 9. Battery pack       | 10. Blade guard          | 11. Switch trigger             | 12. Safety button |
| 13. Oil reservoir cap | 14. Motor cover          |                                |                   |

## 4. TECHNICAL DATA

Model	CS35040VZ DYM120201
Rated voltage	40V d.c.
No Load Chain Speed	5000rpm
Guide Bar Length	14 inch (350mm)
Net weight	5.5 kg
Sound Pressure level at the operator's position	90.3dB(A) K=3 dB(A)
Measured Sound Power level	99.8dB(A) K=2.47dB(A)
Guaranteed Sound Power level	102dB(A)
Vibration	6.75m/s <sup>2</sup> K=1.5 m/s <sup>2</sup>

Lithium-ion Battery						
Model Number	DYMA104	DYMA72E	DYMA81	DYMA151	DYMA154	DYMA155
Rated Voltage	40Vd.c.	40Vd.c.	40Vd.c.	40Vd.c.	40Vd.c.	40Vd.c.
Capacity	5.0AH/180Wh	4.0AH/144Wh	2.5AH/90Wh	2.5AH/90Wh	4.0AH/144Wh	5.0AH/180Wh
Number of Battery	20pcs	20pcs	10pcs	10pcs	20pcs	20pcs

Battery Charger	
Model Number	DYMA83
Input	220-240V~, 50Hz,1A
Output	40Vd.c.,2A
Allowable Charging Temperature Range	0-50℃

## 5. ASSEMBLY

**⚠ WARNING:** Before touching the chain or making any other adjustments, make sure that the tool is switched off and the battery is removed. Always use gloves when handling the chain.

### 5.1 ASSEMBLE THE GUIDE BAR AND SAW CHAIN

1. Wear gloves before assembly. Loosen bar adjustment locking knob counterclockwise one or two full turn.
2. The chain tensioning knob must be rotated counterclockwise until it stops. (Fig.2A)
3. Bar adjustment locking knob should be rotated counterclockwise until it stops. (Fig.2A)
4. Then take off the side cover. (Fig.2B)

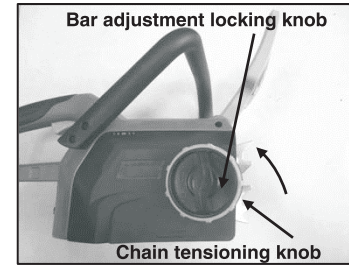

Fig.2A

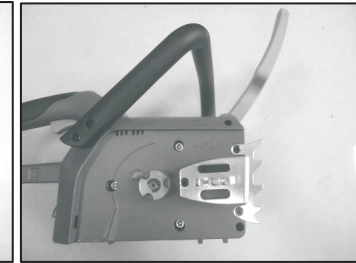

Fig.2B

5. Place the saw chain in the slot of the guide bar, making sure the saw teeth are facing the correct direction by matching the arrow on the guide bar ( Fig. 2C)

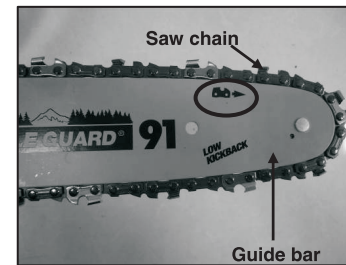

Fig.2C

6. Match the hole of the guide bar with the bolt on the machine (Fig.2D/Fig.2E). Put the guide bar into place (Fig.2F). Place the saw chain around the sprocket with teeth cutting edges facing away from the drive sprocket along top edge of the guide bar. Meanwhile the chain tension knob should be rotated clockwise to its stop to tension the saw chain. (Fig.2G)

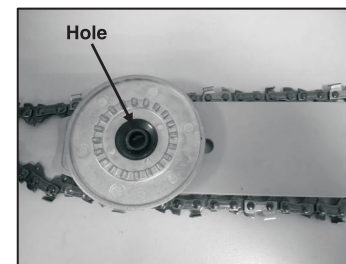

Fig.2D

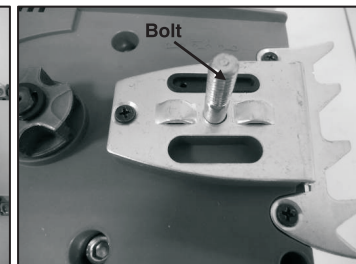

Fig.2E



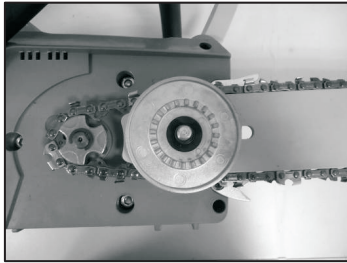

Fig.2F

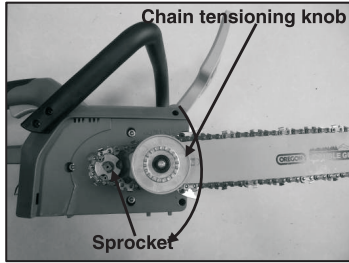

Fig.2G

7. Insert the side cover to the slot and make sure the side cover is securely seated in a fixed way as shown in Fig. 2H/ Fig.2I.

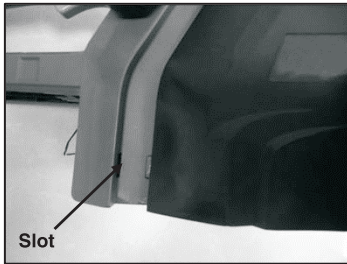

Fig. 2H

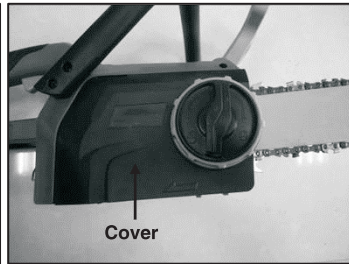

Fig. 2I

8. Making sure the chain properly seated in guide bar rail and guide bar is fixed then locking knob should be rotated clockwise until it stops. (Fig.2J)

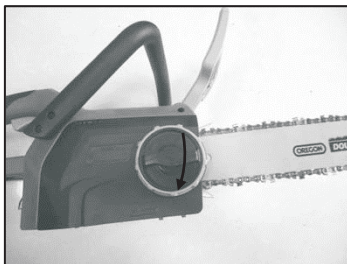

Fig.2J

For adjustment of chain tension please refer to “8.6 ADJUSTING CHAIN TENSION” instruction.

## 5.2 FIT THE GUIDE BAR AND CHAIN COVER. (FIG.3A/ FIG.3B/ FIG.3C)

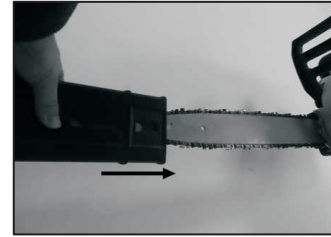

Fig.3A

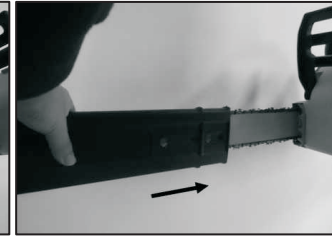

Fig.3B



Fig.3C

**⚠ WARNING:** For you safety and storage, please fit the cutting guard after each operation.

## 5.3 ASSEMBLE THE BATTERY

1. Insert the battery pack into battery holder. (Fig.4A)
2. Make sure the latch on the bottom of battery pack snaps in place and that battery pack is fully seated. (Fig.4B)



Fig.4A



Fig.4B

## 5.4 REMOVE THE BATTERY

1. Press and hold the battery latch button at the bottom of the battery pack.(Fig.5A)
2. Remove battery pack from the product. (Fig.5B)

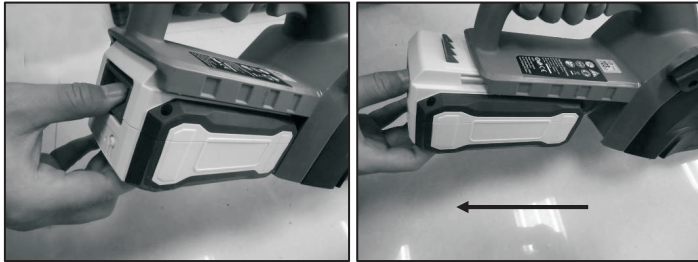

Fig.5A

Fig.5B

## 6. OPERATING THE CHAIN SAW

**⚠ WARNING:** Before working on the device-cleaning, inspection, maintenance or other work-always turn off the device and remove the battery from the device.

### 6.1 ADD LUBRICATION OIL

**⚠ WARNING:** Physical injury due to chain breakage when the chain on the bar is not sufficiently lubricated. Check whether sufficient quantities of chain oil are delivered prior to each use. The method of chain's lubrication is an automatic pump oil.

We recommend using SAE#10W-30 oil or an equivalent mineral chain oil from a specialist supplier.

1. Unscrew the oil cap. (Fig.6A/Fig.6B)
2. Fill chain oil into oil tank, oil lever should be above "MIN" limit. (Fig.6C)
3. Close the oil cap again.

The device must be cleaned thoroughly if oil has been spilled.

**⚠ WARNING:** Avoid dirt or debris entering oil tank.

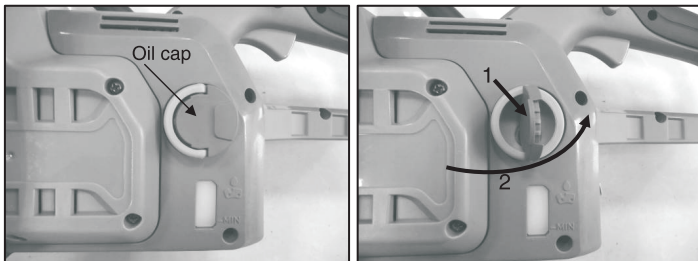

Fig.6A

Fig.6B

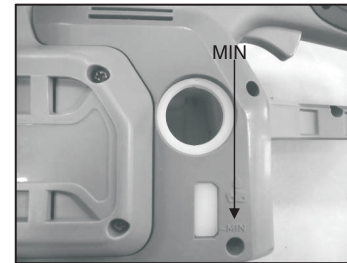

Fig.6C

### 6.2 REMOVE THE BLADE GUARD BEFORE OPERATION. (FIG.7A/ FIG.7B)



Fig.7A

Fig.7B

### 6.3 STARTING THE DEVICE

Hold the rear handle in one hand and hold the front handle in other hand. Press safety button on the rear handle and also press switch trigger. (Fig.8)

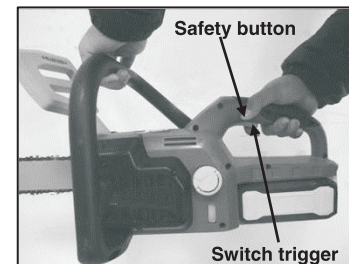

Fig.8

### 6.4 STOPPING THE DEVICE

To stop the Chain saw, release the switch trigger and safety button.

**⚠ WARNING:** If any emergency happens during operation just push forward the hand guard for your personal safety. (Fig.9)

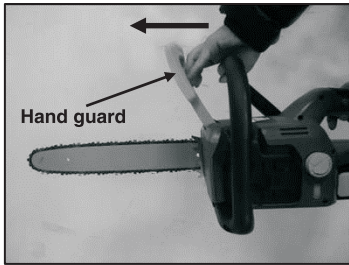

Fig.9

## 6.5 FIT THE GUIDE BAR AND CHAIN COVER. PLEASE REFER TO 5.2

**⚠ WARNING:** For your safety and storage, please fit cutting guard after each operation.

## 7. CUTTING

### 7.1 BASIC CUTTING

**⚠ WARNING:** Always be sure of footing and hold the chain saw firmly with both hands while the motor is running.

1. Assume the proper cutting grip and stance in front of the wood with the saw off. Press the trigger lock-out and squeeze the switch trigger. Let the chain reach full speed before beginning the cut.
2. Begin cutting by lightly pressing the guide bar against the wood. Use only light pressure, letting the saw do the work.
3. Maintain a steady speed throughout the cut, releasing pressure just before the end of the cut.

### 7.2 PRUNING

When pruning, make sure all bystanders or helpers are a safe distance from falling branches and are not directly in front of or behind the saw operator. Secure any branches that might pose a hazard. Use the proper auxiliary equipment. Maintain a good footing, hold the saw firmly with both hands, and do not overreach.

With the saw at full speed, bring the bottom of the guide bar into contact with the branch to be cut. Continue cutting using light pressure. For larger branches, first make a shallow undercut on the bottom of the branch and then finish the cut from the top. Cutting a large branch completely from the top could cause splintering. A complete cut from the bottom can cause the branch to pinch the bar.

### 7.3 FELLING A TREE ( FIG.10 )

When bucking and felling operations are being performed by two or more persons, at the same time, the felling operation should be separated from the bucking operation by a distance of at least twice the height of the tree being felled. Trees should not be felled in a manner that would endanger any person, strike any utility lines or cause any property damage. If the tree does make contact with any utility line, the utility company should be notified immediately.

The chain saw operator should keep on the uphill side of the terrain as the tree is likely to roll or slide downhill after it is felled. A retreat path should be planned and cleared as necessary before cuts are started. The retreat

path should extend back and diagonally to the rear of the expected line of fall.

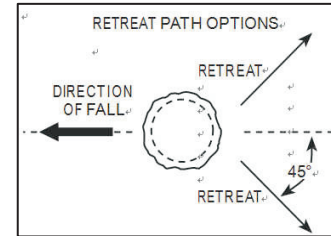

Fig.10

Before felling is started, consider the natural lean of the tree, the location of larger branches and the wind direction to judge which way the tree will fall. Remove dirt, stones, loose bark, nails, staples, and wire from the tree where felling cuts are to be made.

### 7.3.1 NOTCHING UNDERCUT ( FIG.11 )

Make the notch 1/3 the diameter of the tree, perpendicular to the direction of fall. Make the lower horizontal notching cut first. This will help to avoid pinching of either the saw chain or the guide bar when the second notch is being made.

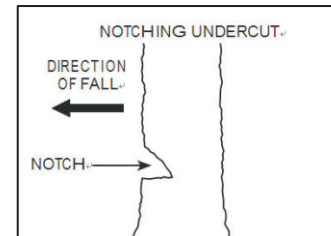

Fig.11

### 7.3.2 FELLING BACK CUT ( FIG.12 )

Make the felling back cut at least 2 inches (51mm) higher than the horizontal notching cut. Keep the felling back cut parallel to the horizontal notching cut. Make the felling back cut so enough wood is left to act as a hinge. The hinge wood keeps the tree from twisting and falling in the desired direction.

Do not cut through the hinge.

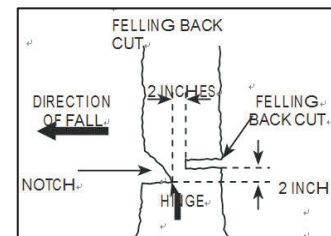

Fig.12

As the felling cut gets close to the hinge the tree should begin to fall. If there is any chance that the tree may not fall in the desired direction or it may rock back and bind the saw chain, stop cutting before the felling back cut is complete and use wedges of wood, plastic or aluminum to open the cut and drop the tree along the desired line of fall.



When the tree begins to fall, remove the chain saw from the cut, stop the motor, put the Chain saw down, then use the retreat path planned. Be alert for overhead limbs falling and watch footing.

### 7.3.3 LIMBING A TREE ( FIG.13 )

Limbing is removing the branches from a fallen tree. When limbing, leave larger lower limbs to support the log off the ground. Remove the small limbs in one cut. Branches under tension should be cut from the bottom up to avoid binding the Chain saw.

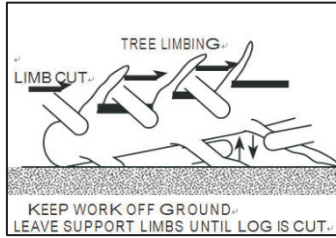

Fig.13

### 7.3.4 BUCKING A LOG

Bucking is cutting a log into lengths. It is important to make sure footing is firm and weight is evenly distributed on both feet. When possible, the log should be raised and supported by the use of limbs, logs or chocks.

### 7.4 FOLLOW THESE SIMPLE DIRECTIONS FOR EASY CUTTING:

When the log is supported along its entire length, it is cut from the top (overbuck). ( Fig.14 )

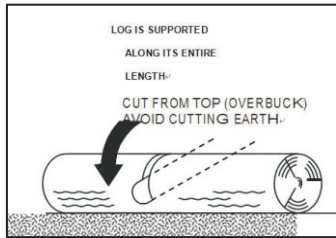

Fig.14

When the log is supported on one end cut 1/3 the diameter from the underside (underbuck). Then make the finished cut by overbucking to meet the first cut. ( Fig.15 )

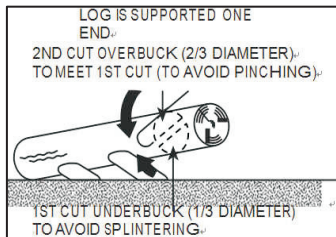

Fig.15

When the log is supported on both ends, cut 1/3 of that diameter from the top overbuck. Then make the finished cut by underbucking the lower 2/3 to meet the first cut. ( Fig.16 )

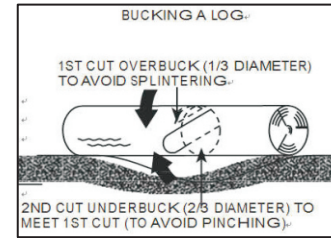

Fig.16

When bucking on a slope always stand on the uphill side of the log. ( Fig.17 )

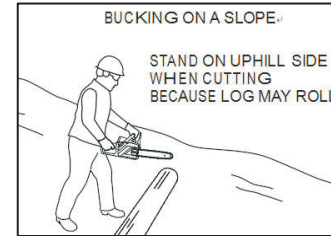

Fig.17

To maintain complete control when cutting through, release the cutting pressure near the end of the cut without relaxing the grip on the chain saw handles. Don't let the chain contact the ground. After completing the cut, wait for the saw chain to stop before you move the chain saw. Always stop the motor before moving from tree to tree.

## 8. MAINTENANCE AND CLEANING

**⚠ WARNING:** Inspect the chain saw. Regular inspection is the first step to proper maintenance. By following the guidelines below, you can maximize safety and satisfaction. Should you identify any damaged or excessively worn parts, replace them immediately.

**⚠ WARNING:** Remove the battery pack from the chain saw. Before inspecting, cleaning, or performing maintenance. A battery operated tool with the battery pack inserted is always on and can start accidentally.

### 8.1 BEFORE EACH USE

- Handles: Front and rear handles should not have cracks or other damage. They should be clean and dry.
- Hand Guard: The hand guard should be free of damage and able to move easily back and forth.
- Guide Bar: The guide bar should be straight and free of chips, cracks, or excessive wear.
- Saw Chain: The chain should be properly tensioned, and all components free of cracks, chips, or excessive wear.
- Side Cover: The side cover should be free of cracks or other damage. It should fit tightly to the saw body with no warping. Make sure the chain catch is free of cracks.
- Battery Pack: The battery pack should be clean, dry, with no signs of puncture, impact, or other damage. The contacts should be clean, dry and free of debris.
- Battery Holder: The battery holder and contacts should be clean, dry, and free of debris.
- Chain Brake: Test the chain brake to make sure it is functioning properly.
- Oil Level: Fill the oil reservoir before use, oil lever should be above "MIN" limit. (Oil reservoir

Capacity:165cc).

j. Motor Cover: Check for cracks in the cover and debris in the air intake vents.

## 8.2 CLEANING THE SAW

**⚠ WARNING:** When cleaning the chain saw power head, do not immerse in water or other liquids.

- Remove the battery pack before cleaning.
- Remove wood chips and other debris from the battery holder. Make sure the contacts are clean and dry.
- After use, clean debris from the chain and guide bar. Wipe the power head with a clean cloth moistened with a mild soap solution. Never use harsh cleaners or solvents.
- Always clean out wood chips, saw dust, and dirt from the bar groove when replacing the saw chain.

## 8.3 PERIODICALLY

- Drive Sprocket: Look for deep grooves, broken teeth, or burrs.
- Bar-Mounting Area: Make sure the bar-mounting stud is not bent, stripped, or cross-threaded and that the bar pad and alignment flange are free of debris and intact.
- Charger: The charger should be clean, dry, and free of punctures or other damage. The battery tray and contacts should be free of debris.

## 8.4 REPLACING THE GUIDE BAR AND SAW CHAIN (FIG.18)

- Wear gloves and the chain saw off and cool and the battery pack removed.
- Loosening bar adjustment locking knob counterclockwise one or two full turn.
- The chain tensioning knob must be rotated counterclockwise to its stop.
- Bar adjust locking knob should be rotated counterclockwise to its stop.
- Then take off the side cover.
- Last you can take off the worn bar and chain and make sure the bar pad, sprocket, and tensioning knob are free of debris.

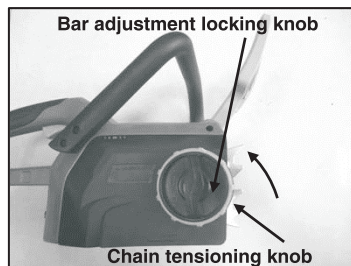

Fig.18

## 8.5 INSTALL NEW GUIDE BAR AND SAW CHAIN

PLEASE REFER TO 5.1

## 8.6 ADJUSTING CHAIN TENSION

**⚠ WARNING:** Sharp moving chain. To prevent accidental operation, ensure that battery is removed from the tool before performing the following operations. Wear protective gloves.

- Loosening bar adjust locking knob counterclockwise one or two full turn.
- Chain tensioning knob must be rotated clockwise to its suitable turn to adjust chain tension.
- With the saw on a firm surface, check the saw chain tension. The tension is correct when the chain snaps back after being pulled 1/8 inch (3mm) away from the guide bar with light force from the middle finger and thumb as shown in figure (Fig.19A). There should be no "sag" between the guide bar and the chain on the underside as shown in figure. (Fig.19B)

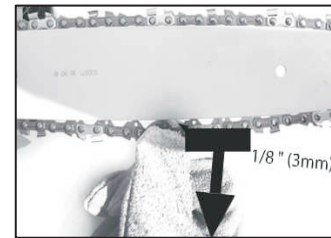

Fig.19A

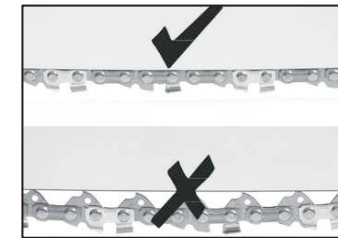

Fig.19B

- Once chain tension is correct, securely tighten bar adjust locking knob clockwise to stop.
- When the chain is new, check the tension frequently (after removing battery) during the first 2 hours of use as a new chain stretches slightly.

## 9. TROUBLESHOOTING

The following chart lists problem symptoms, possible causes and corrective action, if your garden product does not operate properly. If these do not identify and correct the problem, contact your service agent.

**⚠ WARNING:** Switch off and remove the battery prior to any troubleshooting.

Fault	POSSIBLE CAUSE	Remedial Action
Motor does not run or runs intermittently	Chain brake engaged.	Before starting, make sure the hand guard is in its most rearward position (chain brake disengaged). For correct hand guard position, see "Starting The Saw" in this manual
	Battery discharged	Check the charge-level indicator on the battery. If no green indicator lights are on recharge
	Trigger lock-out not pressed	Trigger lock-out must be depressed. See "Starting The Saw" in this manual
	Battery pack not fully inserted	Clean debris from the battery port and terminals with a clean dry cloth or non-conductive brush
	Debris in side cover	Remove battery pack, then remove side cover and clean out debris.
Motor runs, but chain does not rotate	Battery pack cold	Allow battery to warm above the minimum operating temperature of 10°F (-12°C).
	Chain not engaging drive sprocket	Reinstall the chain, making sure the drive links on the chain are fully seated on the sprocket. See "Maintenance and Cleaning" in this manual for installation instructions
Chain brake does not engage	Debris preventing full movement of hand guard	Clean debris from external chain brake mechanism
	Possible chain brake malfunction	Contact an approved service location immediately
Chain saw does not cut properly	Insufficient chain tension	See "Tensioning Instructions" in this manual
	Chain installed backwards	See "Replacing the Bar and Chain" in this manual
	Worn chain	Replace both the chain and bar. They are designed to wear at the same rate
	Dry or excessively stretched chain	Check the oil level. Refill oil reservoir if necessary. See "Assembly" in this manual. Check for a clogged oil system. A small amount of oil should be delivered to the bar
	Chain not in bar groove	See "Replacing the Bar and Chain" in this manual.

## 10. WARRANTY

This product is warranted in accordance with legal regulations for a 24 month period effective from the date of purchase by the first user.

This product will not be covered if used in a commercial application.

This warranty covers all material or production failures, it does not include: defects from normal wear and tear, parts such as, bearings, brushes, cables, air cleaning elements, brake pad, clutch disc, tyre, wheel, recoil starter rope, belts, cutter blades, plugs, lubricant oils and grease or accessories. Damage or defects resulting from abuse, accidents or alterations, natural fading of painted or plated surfaces, sheet peeling and other natural deterioration.

Any damage that occurs from the use of non-genuine Cobra parts will not be covered.

We reserve the right to reject any claim where the purchase cannot be verified or when it is clear that the product was not maintained properly. (Clean ventilation slots, carbon brushes and serviced regularly)

Expenses incidental to the warranty claim that are not covered;

-Compensation for loss of time, commercial loss or rental costs of substitute product.

-Costs incurred for transportation to and from the dealership.

Any damage that occurs from the following will not be covered; exposure of the product to smoke and soot, chemical agents, bird droppings or other animal waste, seawater, sea breeze, salt or other environmental phenomena.

Any damage resulting from operating methods other than those indicated in the owner's manual will not be covered.

Your purchase receipt must be kept as proof for date of purchase. Your un-dismantled product must be returned to your dealer in an acceptably clean state, accompanied by your proof of purchase.

### Please Register Your Product:

If your dealer did not collect registration information from you, please take a few minutes and register your purchase with Cobra.

You can register by going online to: [www.cobragarden.co.uk](http://www.cobragarden.co.uk) and clicking on Product Registration.

Before using the lawn mower, all mower operators must read this manual

## 11. ENVIRONMENTALLY FRIENDLY DISPOSAL



According to EU directive 2012/19/EU on electric and electronic equipment and its implementation into national law, all electric tools must be separately collected and environmentally friendly recycled. Alternative disposal: If the owner of the power tool does not return the tool to the manufacturer, he is responsible for proper disposal at a designated collection point that prepares the device for recycling according to national recycling laws and regulations.

This does not include accessories and tools without electric or electronic components.

## 12. EC-DECLARATION OF CONFORMITY

EC Declaration of Conformity	
We herewith declare,	Cobra Garden Machinery, Henton & Chattell Ltd, London Road, Nottingham NG2 3HW UK
That the following machine complies with the appropriate basic safety and health requirements of the EC Directive based on its design and type, as brought into circulation by us.	
In case of alteration of the machine, not agreed upon by us, this declaration will lose its validity	
Product	Cordless Chainsaw
Machine Type	CS35040VZ (DYM120201)
Rated voltage	40V d.c.
Bar length	350mm
Measured Sound Power level	99.8dB(A)
Guaranteed Sound Power level	102dB(A) Notified Body for EC Directive 2000/14/EC:0036 TüV SÜD Industrie Service GmbH Westendstrasse 199 . 80686 München . Deutschland
Applicable EC Directives	EC Directive of Electromagnetic Compatibility 2014/30/EU EC Machinery Directive 2006/42/EC EC Directive of noise emission 2000/14/EC RoHs Directive 2011/65/EU
Applicable Harmonized Standards	EN 60745-1 EN 60745-2-13 EN 55014-1 EN 55014-2
Authorized Signature/Date/ Place	 Peter J. Chaloner 05/06/2020
Title of Signatory	Managing Director
Name and address of the person authorized to compile the technical file	Cobra Garden Machinery, Henton & Chattell Ltd, London Road, Nottingham NG2 3HW UK